

TX7130

Conventional Reflective Beam Detector



Feature and Benefits

- EN54-12 Listed
- Hassle free alignment, built with digital guide display and laser beam pointing
- Employ single-ended design through reflective mirror
- Four ranges wide monitoring from 8-100 meters via encoder
- Three users programing sensitivity adjustment
- Built-in microprocessor
- Self-diagnosis function can monitor for internal faults
- Automatic compensation for factors weakening received signals, such as dust contamination, positional movement and ageing of the transmitter
- Fire and Fault interfacing relays
- Attractive and pleasing appearance
- Real User friendly alignment method



1330a-(cl-1)



0832-CPR-F1301

Overview

TX7130 Conventional Reflective Beam Detector has built in Laser beam pointing and Digital guide display for real user friendly alignment method. The Laser beam pointing accurately point the exact location where to mount mirror and with additional digital guide display allows to monitor and guide on the actual light intensity between the mirror and detector which cannot be seen by our naked eye making it more easy and convenient in alignment commissioning.

The TX7130 has four adjustable operational ranges of between 8 to 20, 20 to 40, 40 to 70 and 70 to 100 meters beside with three adjustable sensitivity setting ranges from 2.6dB, 3.8dB and 5.8dB to meet the specific environmental requirement. The TX7130 works on the principle of reflective infrared beam obscuration. Used in conjunction with a reflector, it will notify the fire alarm panel when the infrared beam is obscured by smoke.

The TX7130 is ideal for use high ceiling and wide areas such as warehouses, large storages, shopping malls, leisure centres, exhibition halls, hotel lobbies, printing houses, garment factories, museums and prisons, as well as places where slight smoke particles or corrosive gas exist.



Technical Specification

Part Number

TX7130

Standard

Listed
Compliance
Fire Detection and Alarm Systems

LPCB / CE-CPR
EN54-12
BS 5839 Part 1:2002

Specification

Operating Voltage
Current Parameters
Beam Sensor Sensitivity [via Encoder]

20 V to 28 V DC
Standby:23mA Commission:56mA Alarm:33mA
Level 1: 2.6 dB High Sensitivity
Level 2: 3.8 dB Medium Sensitivity
Level 3: 5.8 dB Low Sensitivity

Beam Pathway Length [via Encoder]

Span 1: 8 to 20 meters Short Path (1x mirror reflector required)
Span 2: 20 to 40 meters Short Path (1x mirror reflector required)
Span 3: 40 to 70 meters Normal Path (4x mirror reflector required)
Span 4: 70 to 100 meters Long Path (4x mirror reflector required)

Beam Path Angle

±0.5° Directional

Alignment Guide

Laser Beam Pointer

Digital Display Guide

Nixie Tube

LED Indicator Guide

Red: Fire; Yellow: Fault; Green: Alignment

Reset Time

Less than 2 Second (Power Cut)

Relay Capacity [Fire & Fault]

Normally Open/ 2.0 A; 30 VDC

Physical

Material / Colour
Dimension / Weight
Weight

ABS / White
L:190.87 x W:126.87 x H:91.96 mm / 440 gm
0.130 Kg with base

Accessories

Mounting Bracket/ TX7130-R 4 x Mirror Reflector

Environmental

Operating Temperature / Protection Rating

-10°C to 55°C / IP30 [IP66 glue seal-For permanent fixing]

Humidity

0 to 95% Relative Humidity, Non condensing



Mounting Details

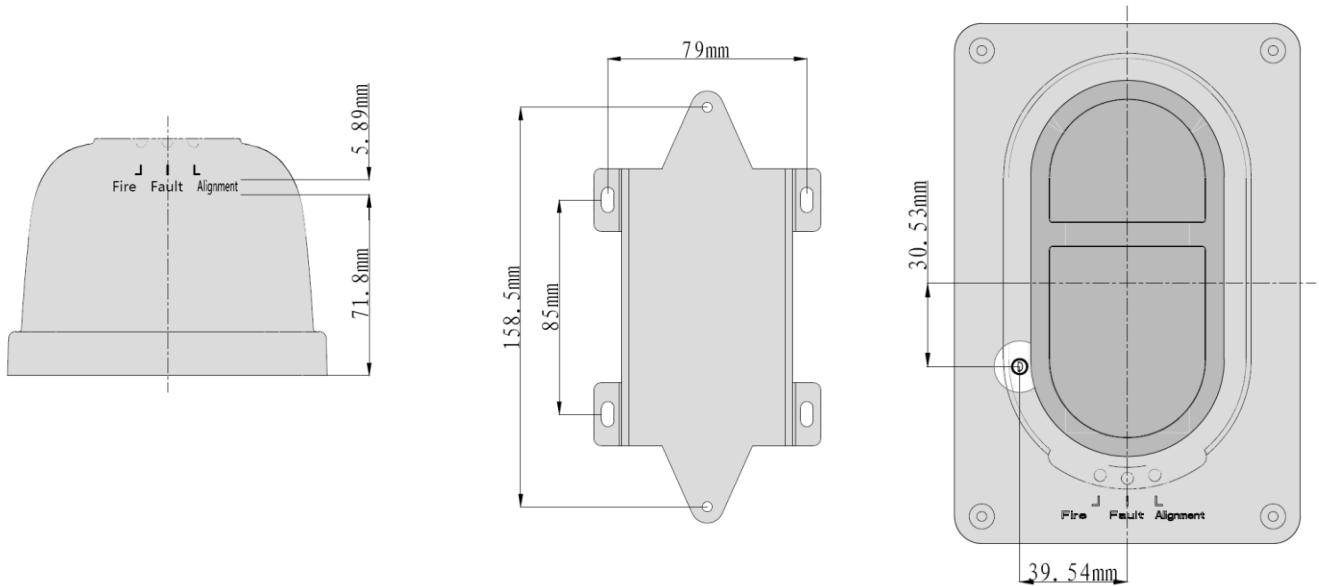

Names and Locations

